

Tools Required:

STEP 1

REMOVE DRIVE STUDS
FROM PANEL
TO BE ROTATED

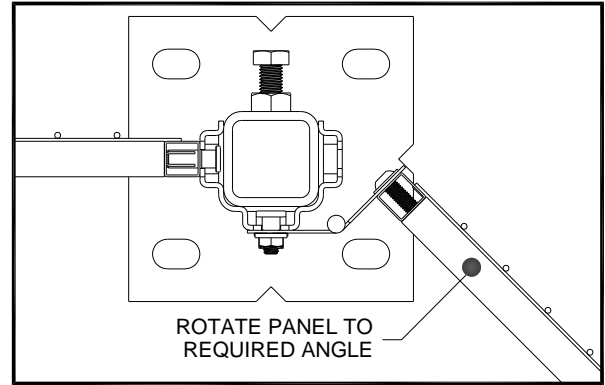

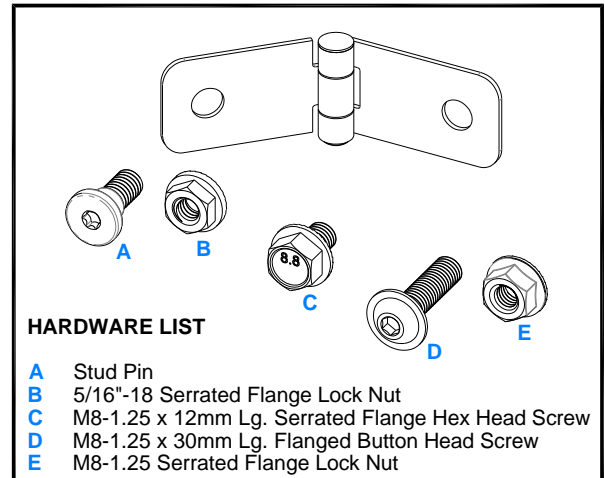
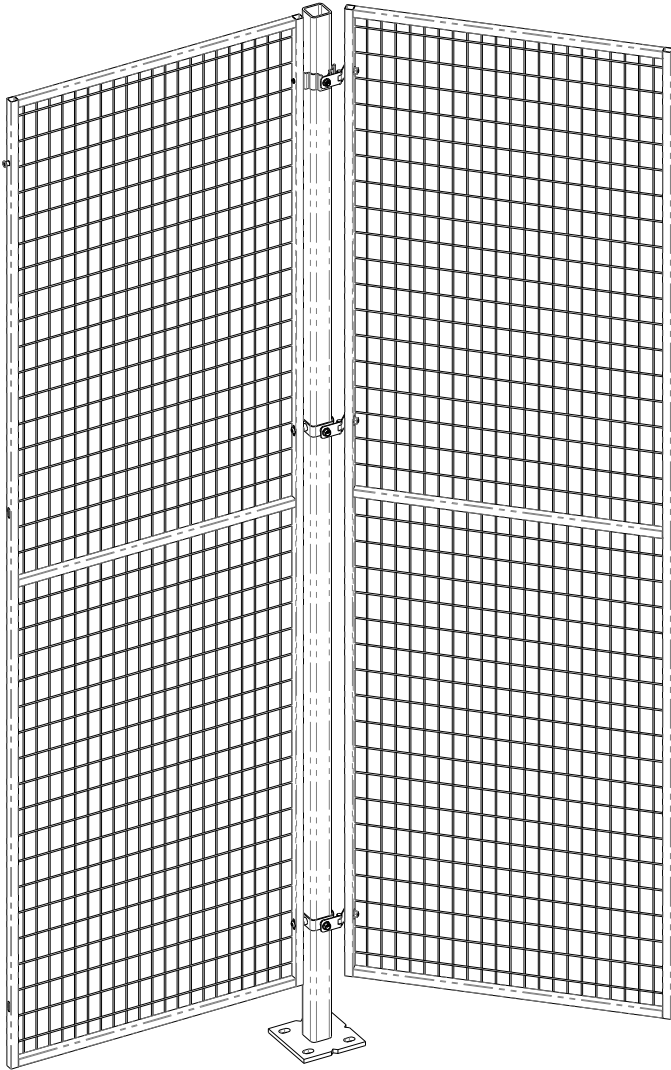
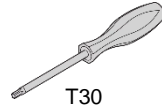
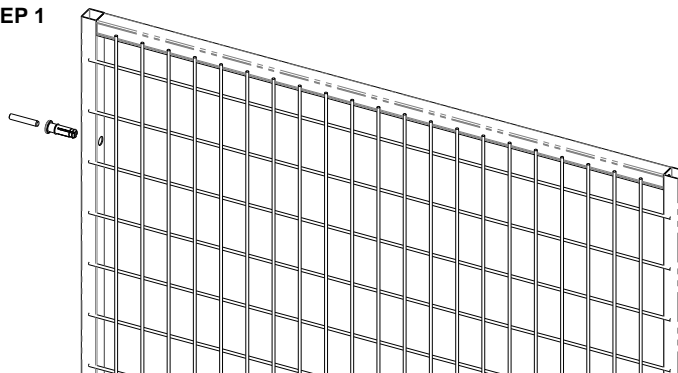
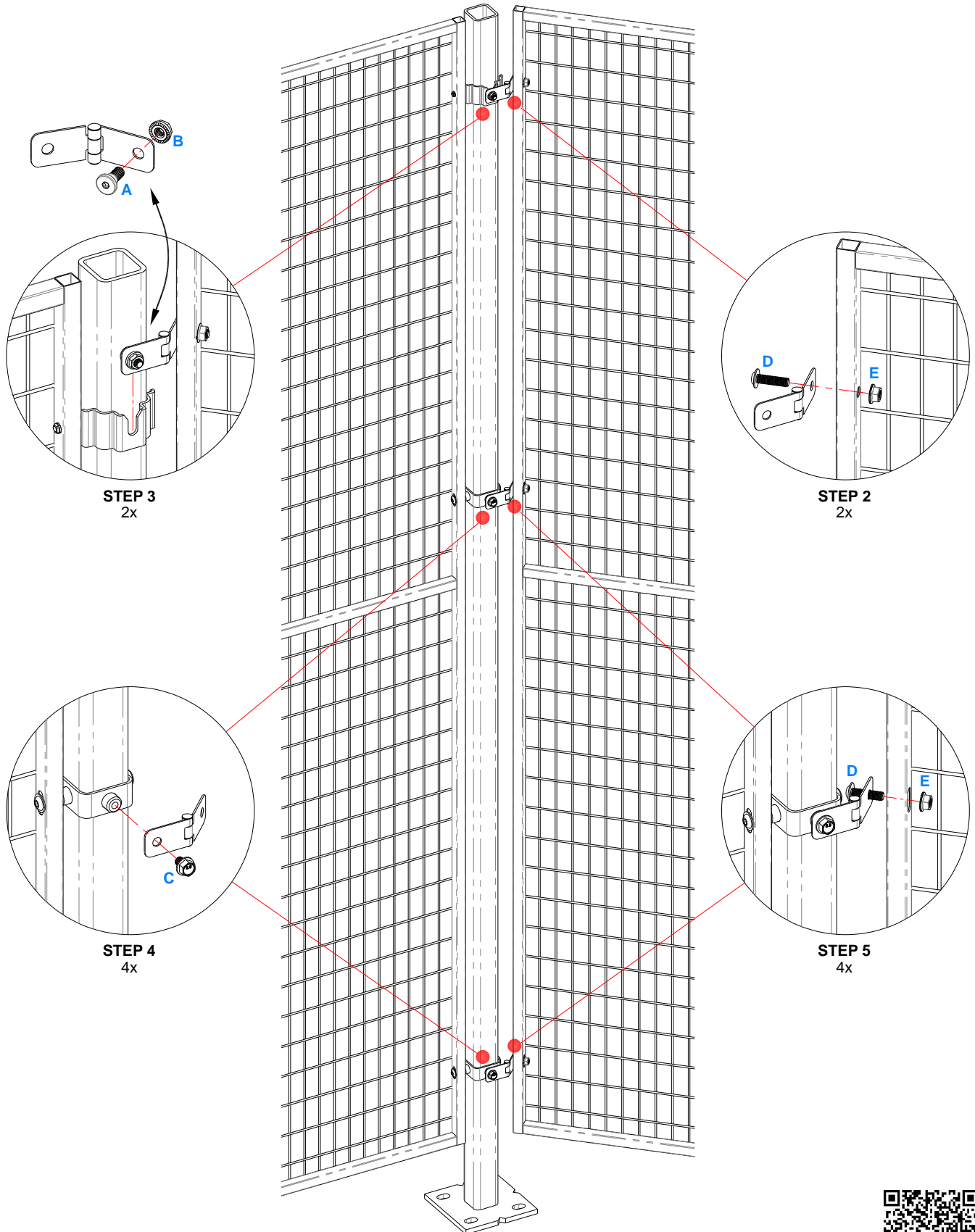

Fence Panel Adjustable Width Kit

Extends Panels 50 to 199mm

Installation Instructions

FGI-397
9-1-2024

Tools Required:



Drill



5/16"
or 8mm

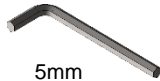

5mm
or 3/16"

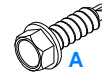

A

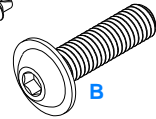

B

HARDWARE LIST

- A #12-14 x 3/4" Lg. Hex Head Self-Drilling Screw
- B M8-1.25 x 30mm Lg. Button Head Cap Screw

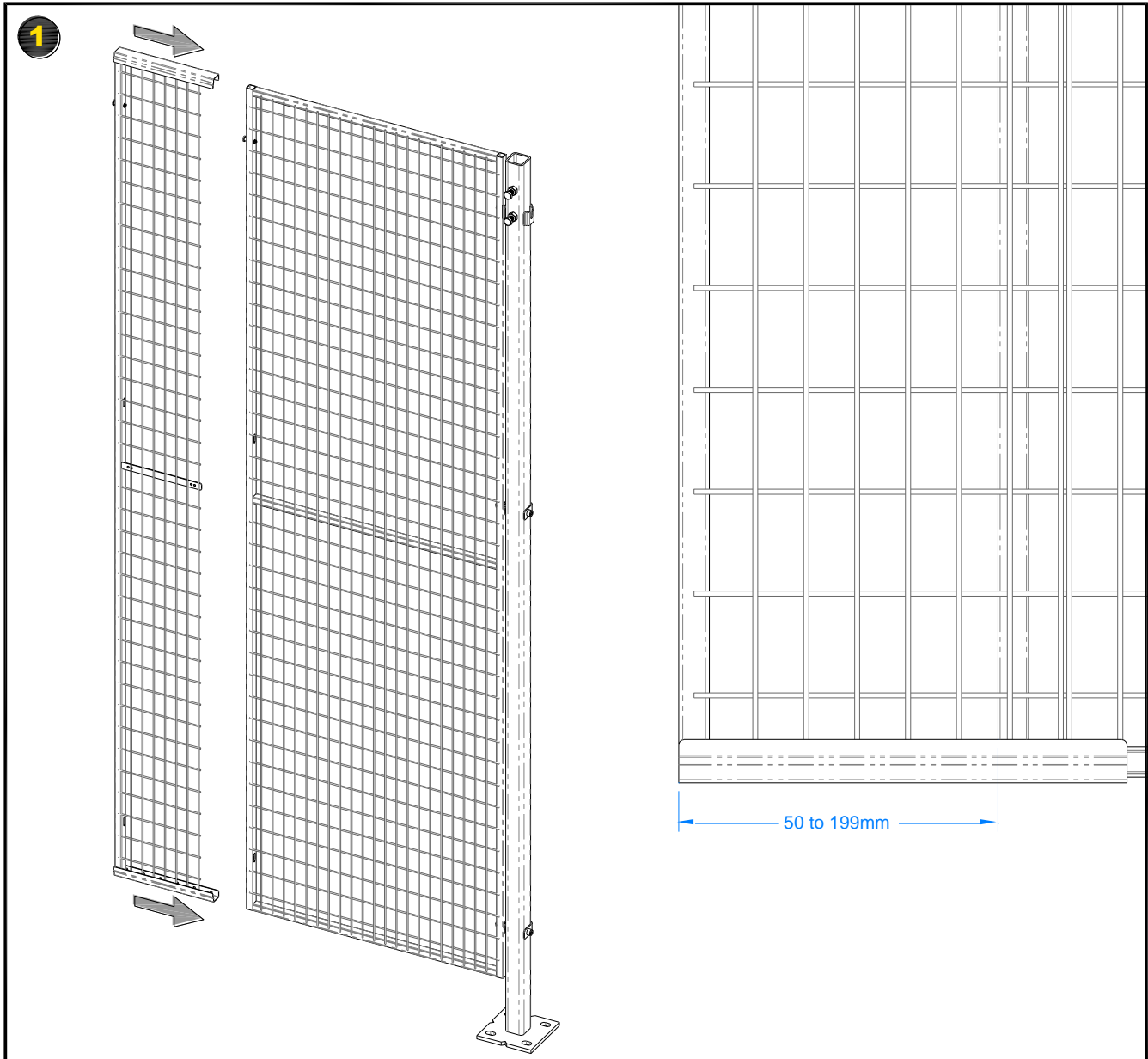



Fence Panel Adjustable Width Kit

Extends Panels 50 to 199mm

Installation Instructions

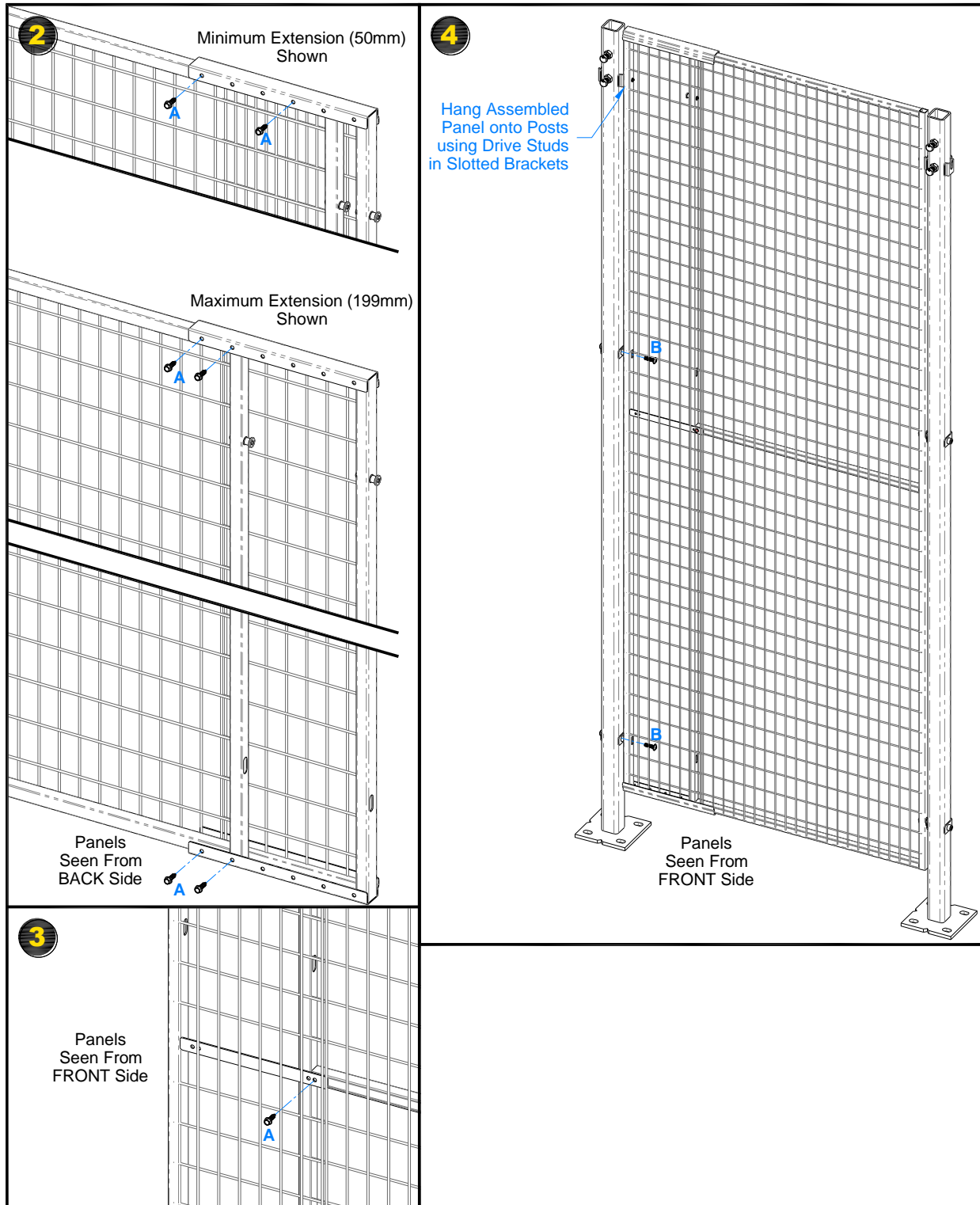

Tools Required:

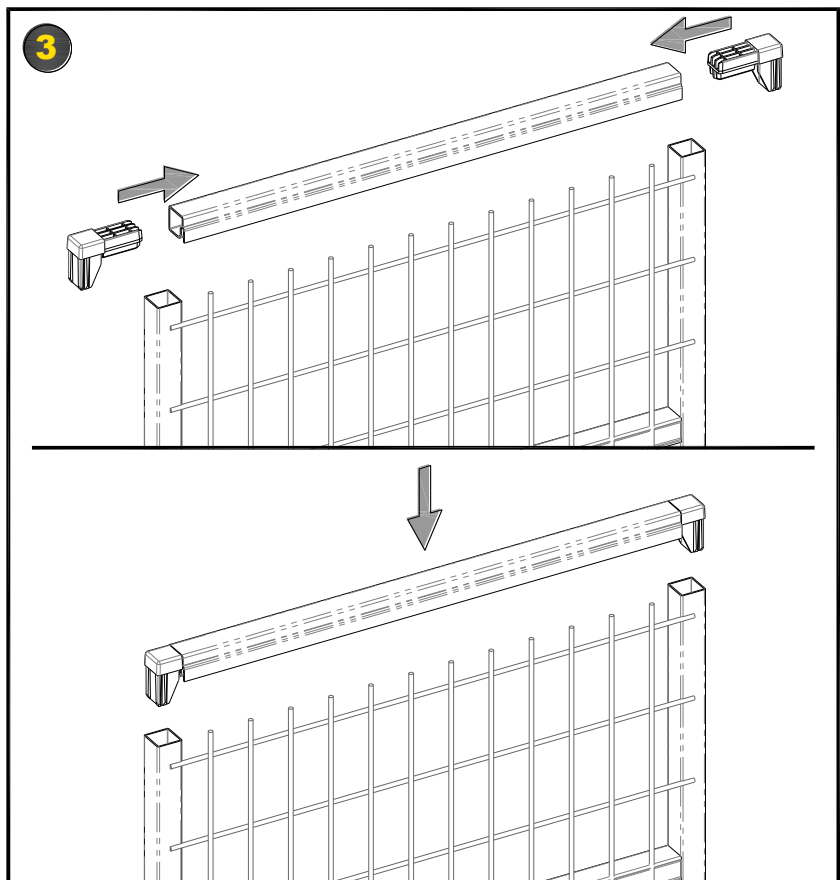
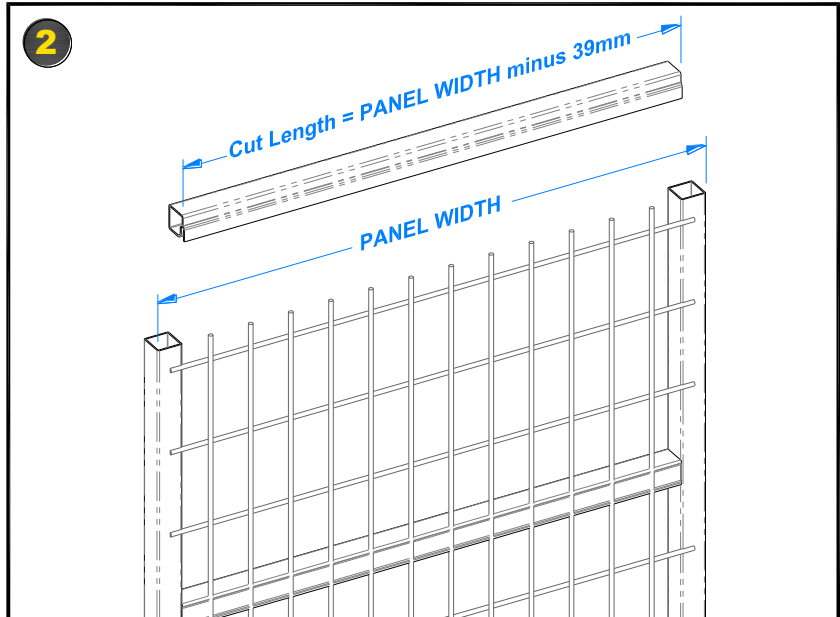
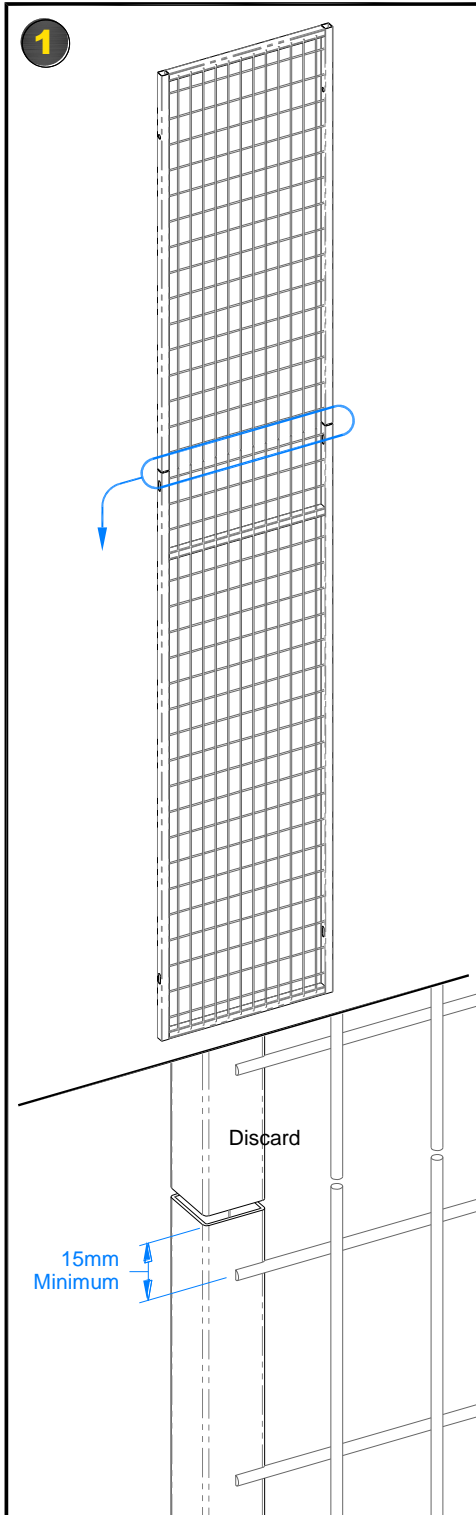

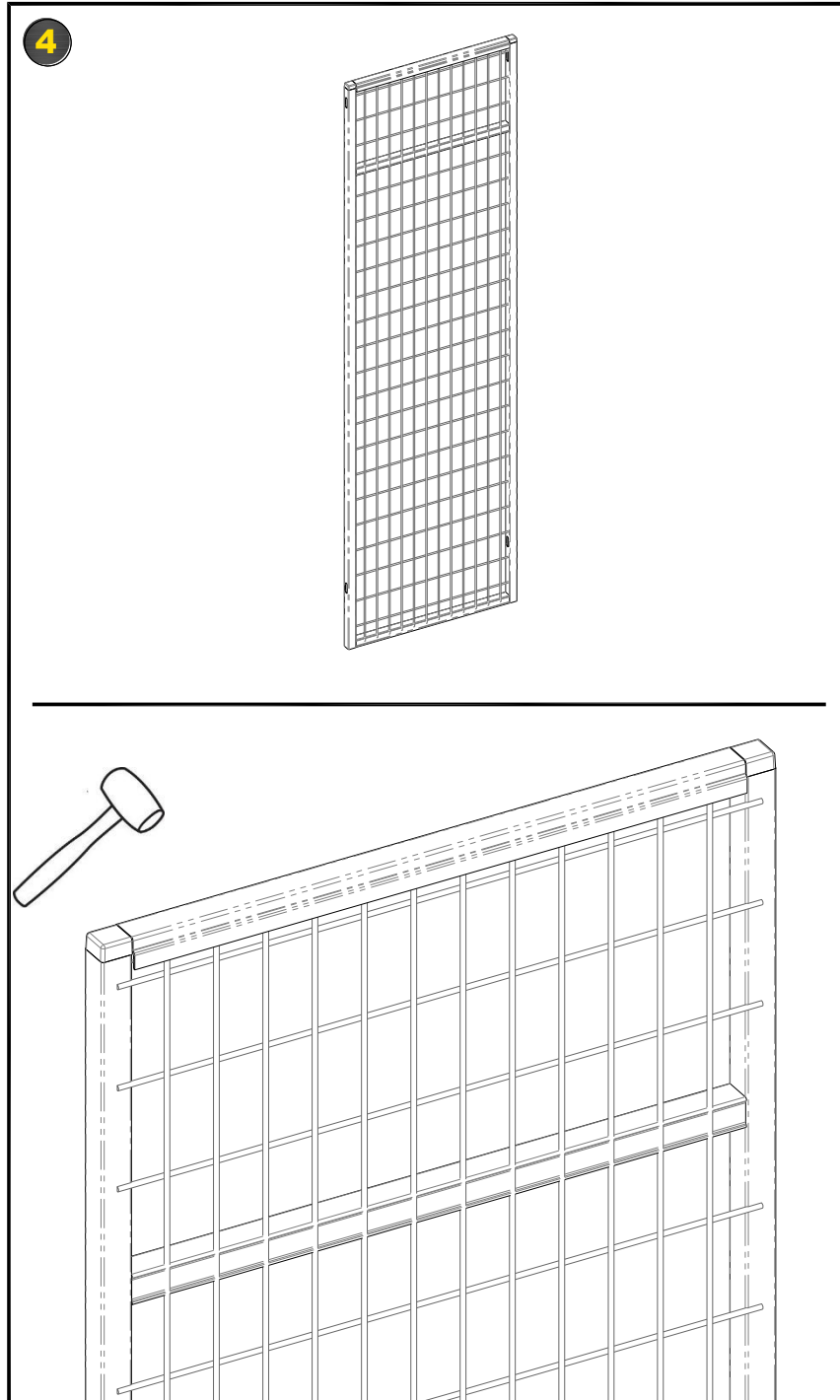

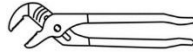
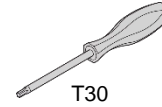
Tools Required:

 13mm
 or 1/2"

T30

HARDWARE LIST

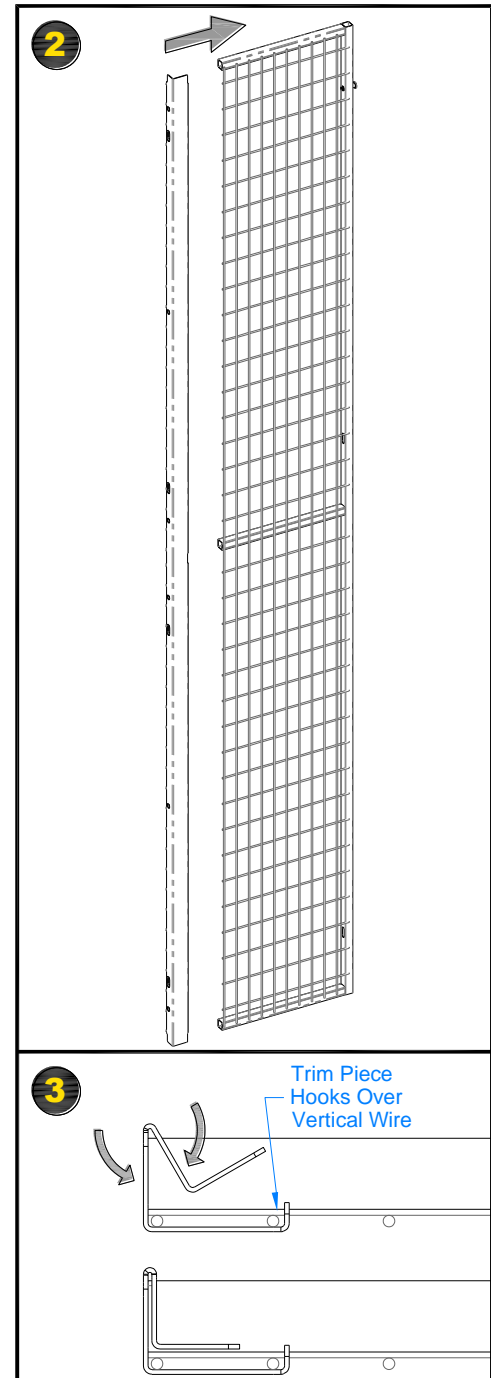
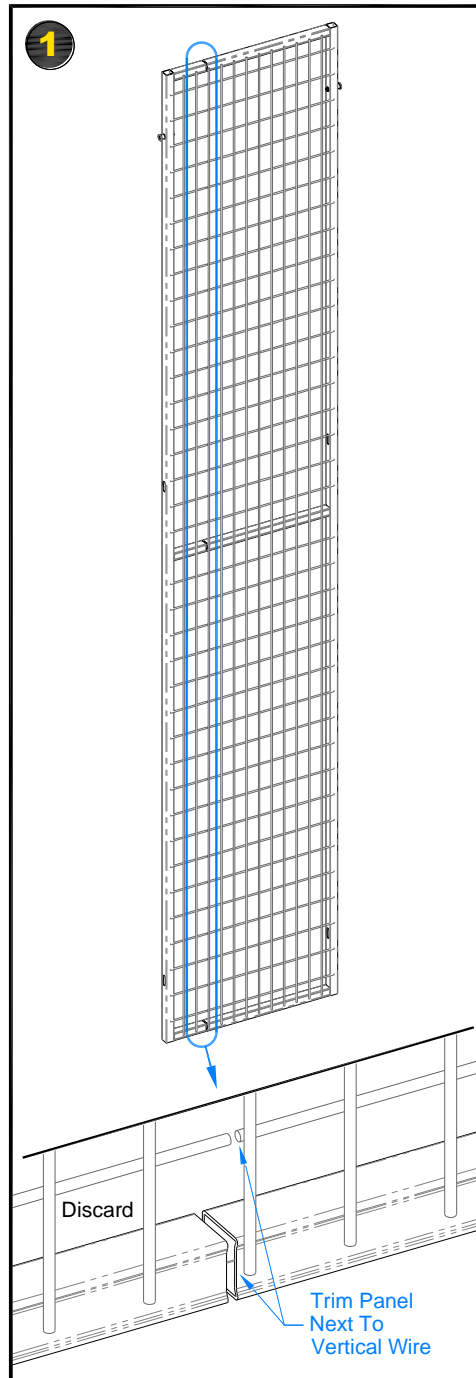
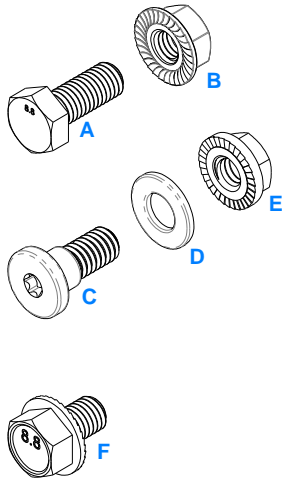
- A** M8-1.25 x 20mm Lg. Hex Head Cap Screw
- B** M8-1.25 Serrated Flange Lock Nut
- C** Stud Pin
- D** 5/16" Flat Washer
- E** 5/16"-18 Serrated Flange Lock Nut
- F** M8-1.25 x 12mm Lg. Serrated Flange Hex Head Screw

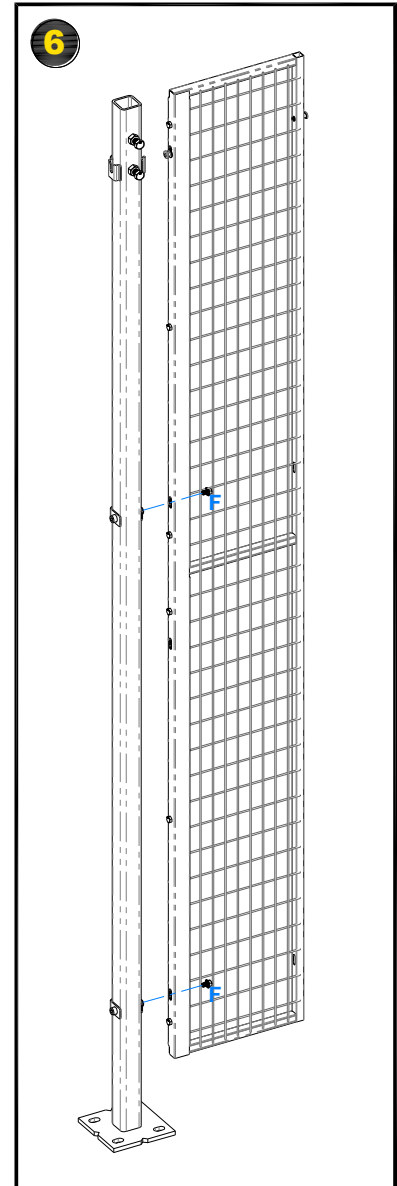
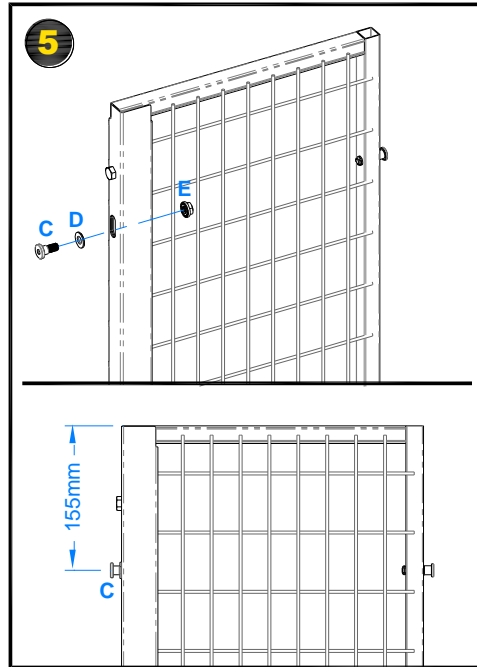
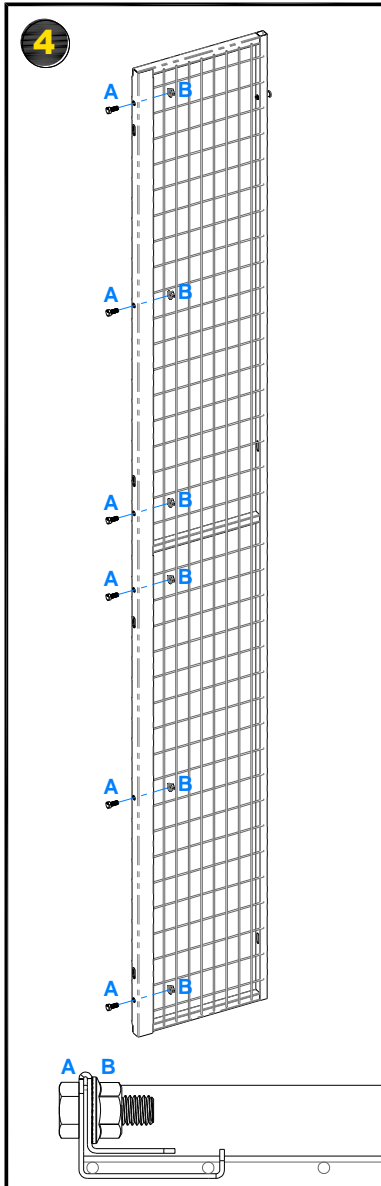



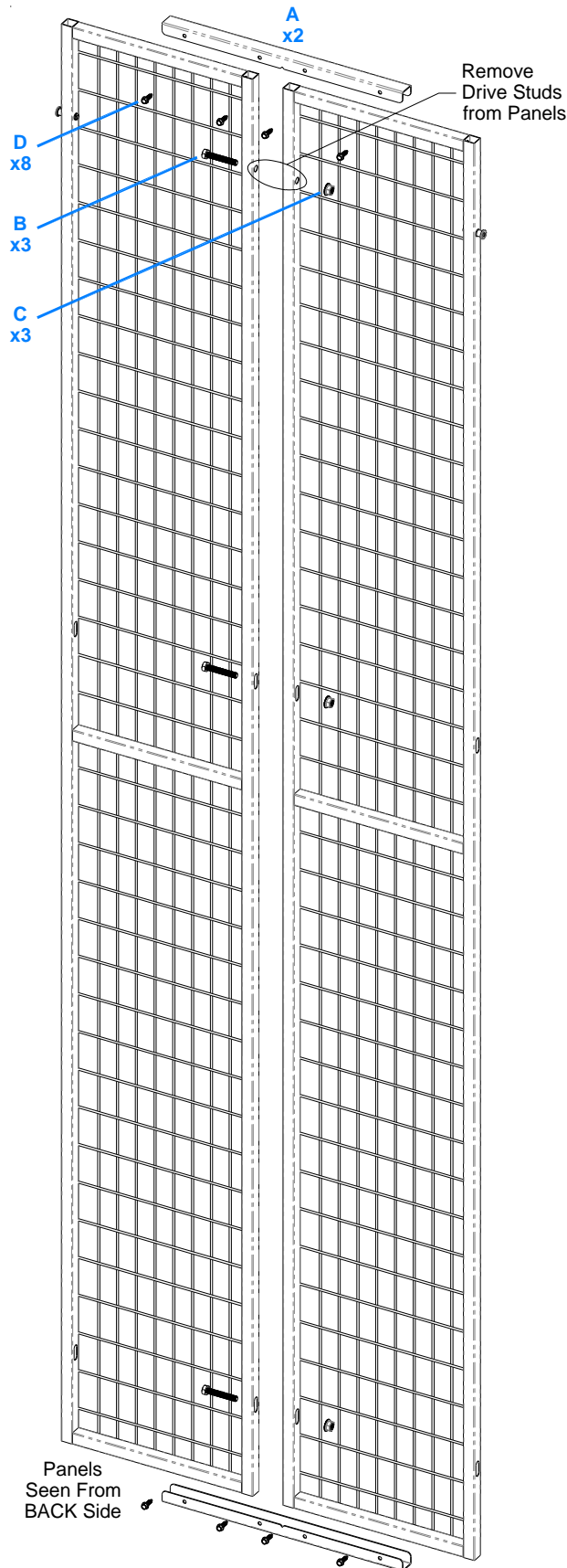

PARTS LIST

- A** U-Channel Stiffener Bracket
- B** M8-1.25 x 50mm Lg. Hex Cap Screw
- C** M8-1.25 Serrated Flange Lock Nut
- D** #12-14 x 3/4" Lg. Hex Head Self-Drilling Screw

