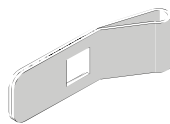
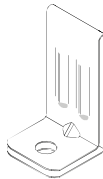
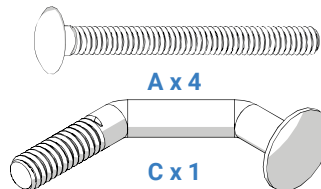
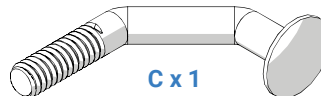

**KT6075**  
 x2

**FGB-331P**  
 J x 2

**FGB-330B**  
 H x 3

**FGB-332P**  
 G x 4

**FGB-42**  
 F x 1

**A x 4**

**C x 1**

**D x 1**

**B x 5**

**E x 1**

HARDWARE KIT USE TO INSTALL VERSA GUARD

**HARDWARE LIST**

A	1/4"-20 x 2-1/2" Carriage Bolt Carbon Zinc
B	1/4"-20 Zinc-Plated Serrated Flange Lock Nut
C	1/4"-20 x ?" Carriage Bolt Carbon Zinc
D	#14-10 x 1-1/4" ZINC-PLATED METAL SCREW
E	#14 X 1" TUBULAR ANCHOR

1

REFERENCE POST INSTALLATION (FGI-391) BEFORE CONTINUING TO THE NEXT STEPS

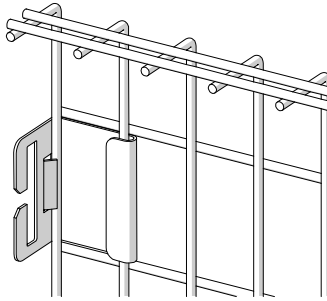
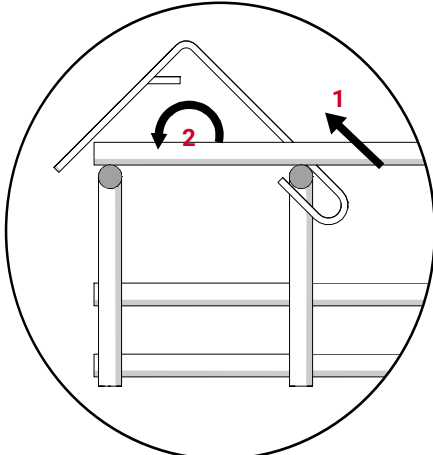
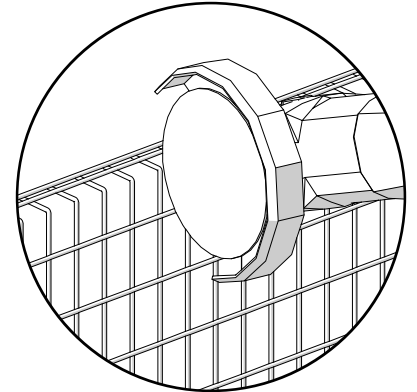

ROTATE CLIP ONTO VERSA GUARD PANELS ON EACH SIDE

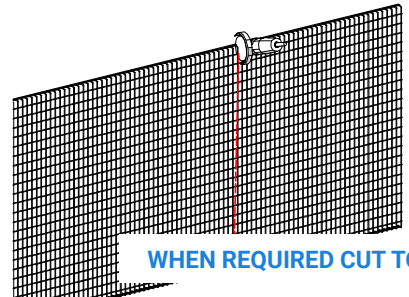

WHEN REQUIRED CUT TO SIZE

2

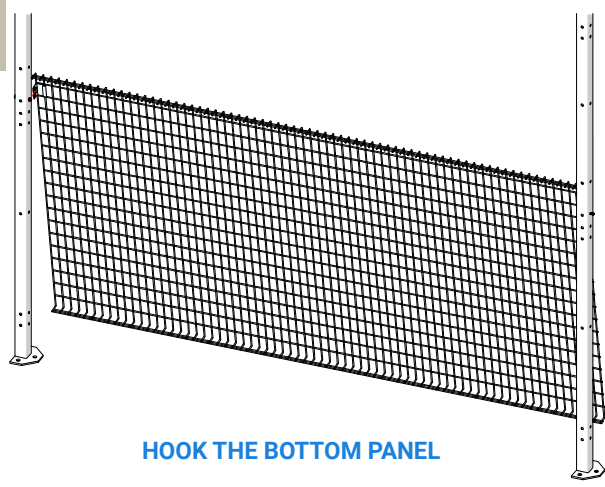

HOOK THE BOTTOM PANEL

3

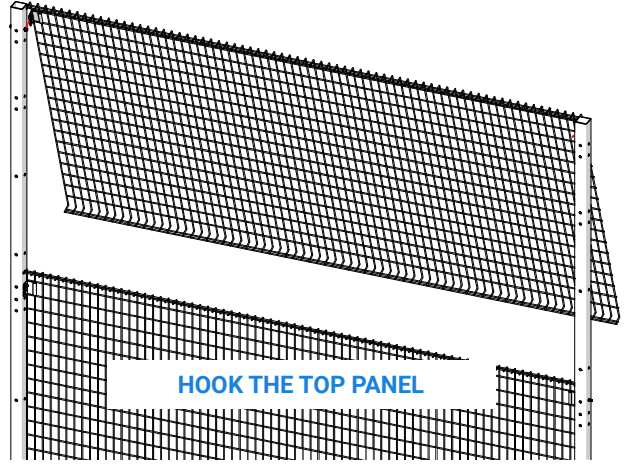

HOOK THE TOP PANEL

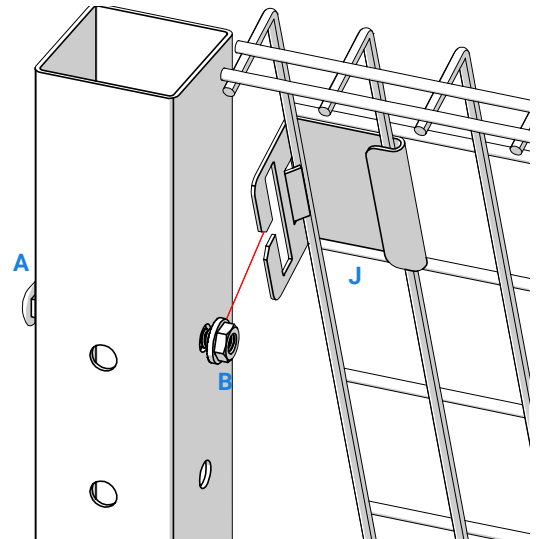
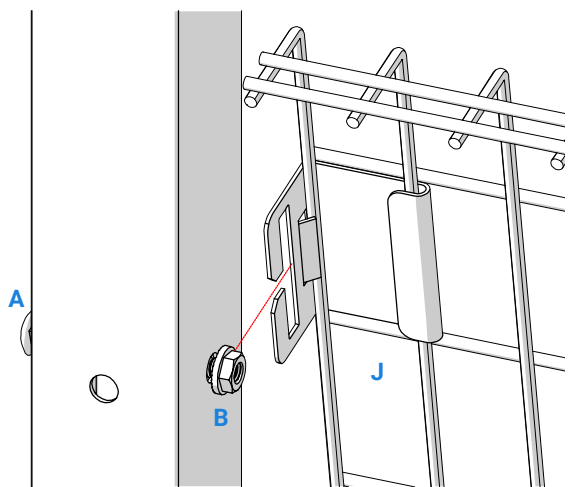

63" H GUARDING

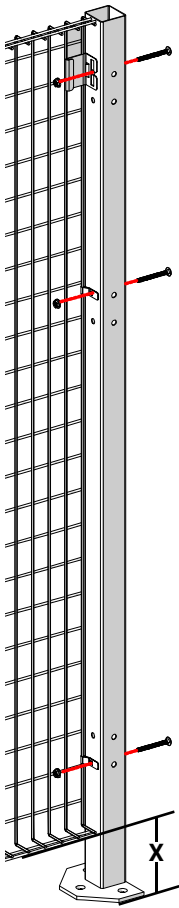

84" H GUARDING

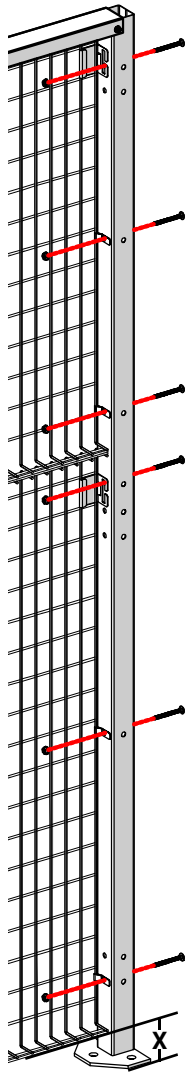

96" H GUARDING

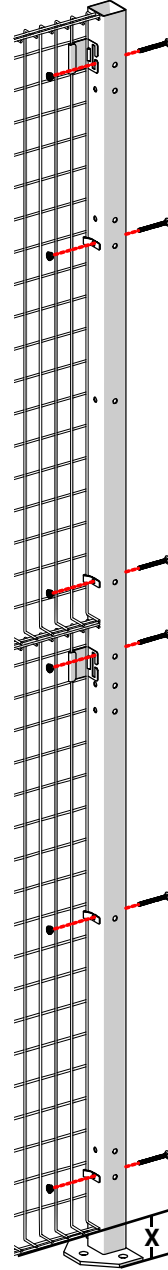

120" H GUARDING

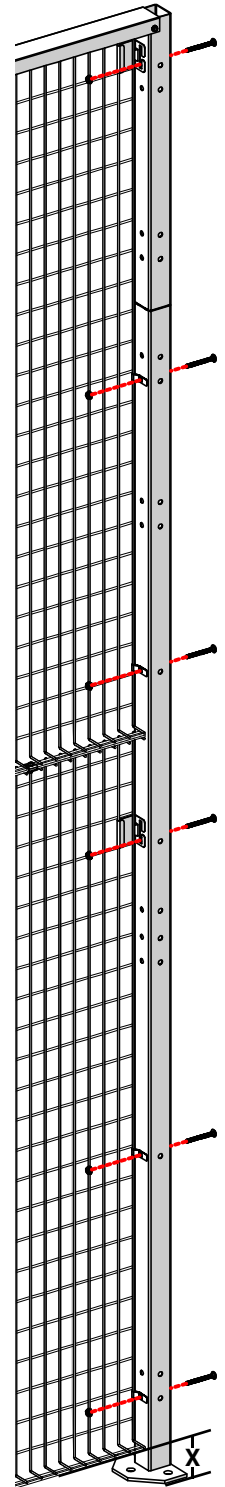

**SWEEPS**  
 FOR 63" H GUARDING X= 4"  
 FOR 84", 96", AND 120" H GUARDING X=2"

**PANEL CONFIGURATIONS**

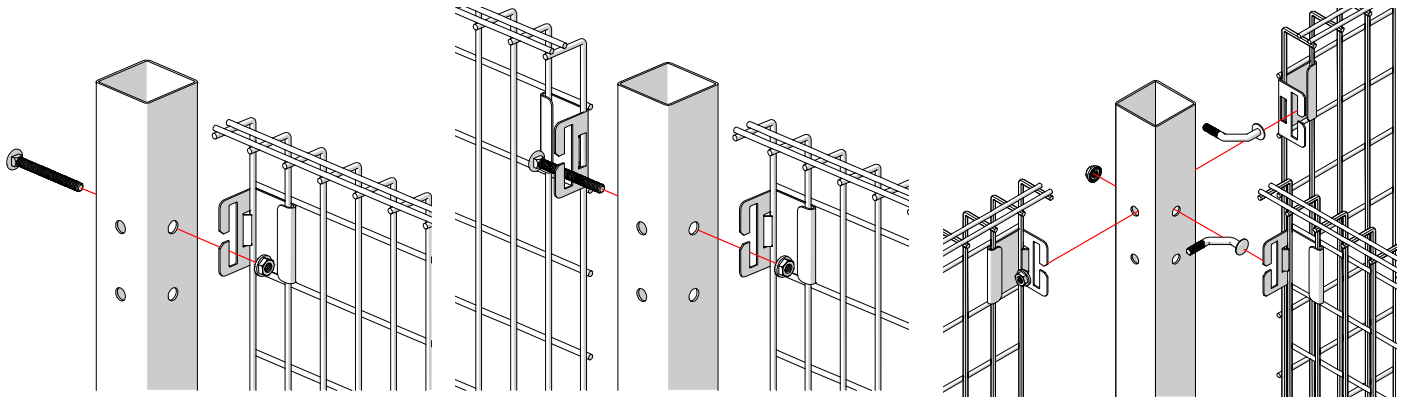

**END**

**LINE**

**3 - WAY**

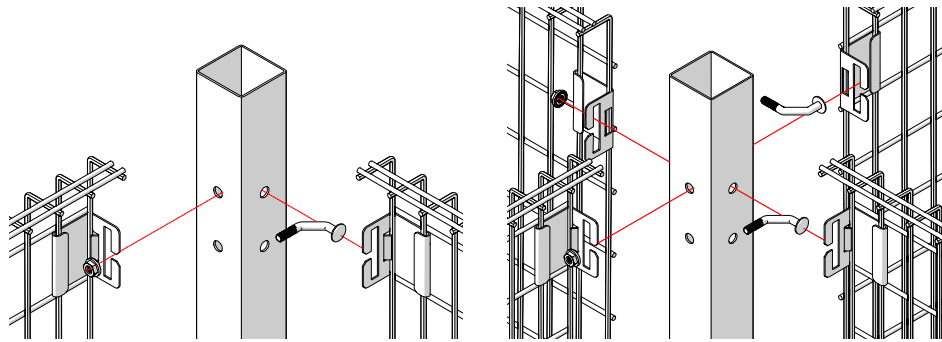

**CORNER**

**4 - WAY**

**5**

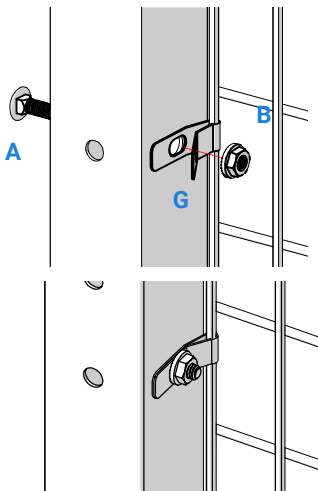

**SECURE PANELS WITH A CLIP (G)**

**6**

**ALIGN WIRES TO A STACK LAYOUT AND SECURE WITH A (H) CLAMP**

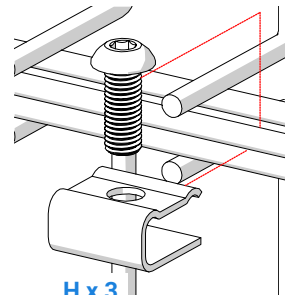
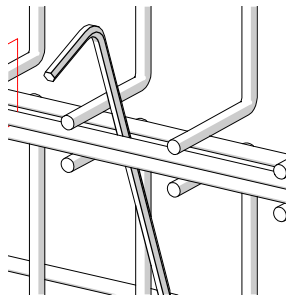
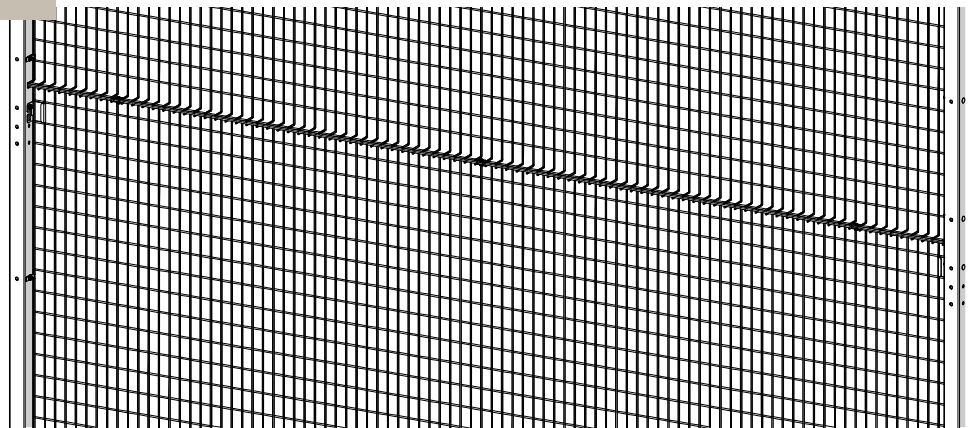

**H x 3**

7

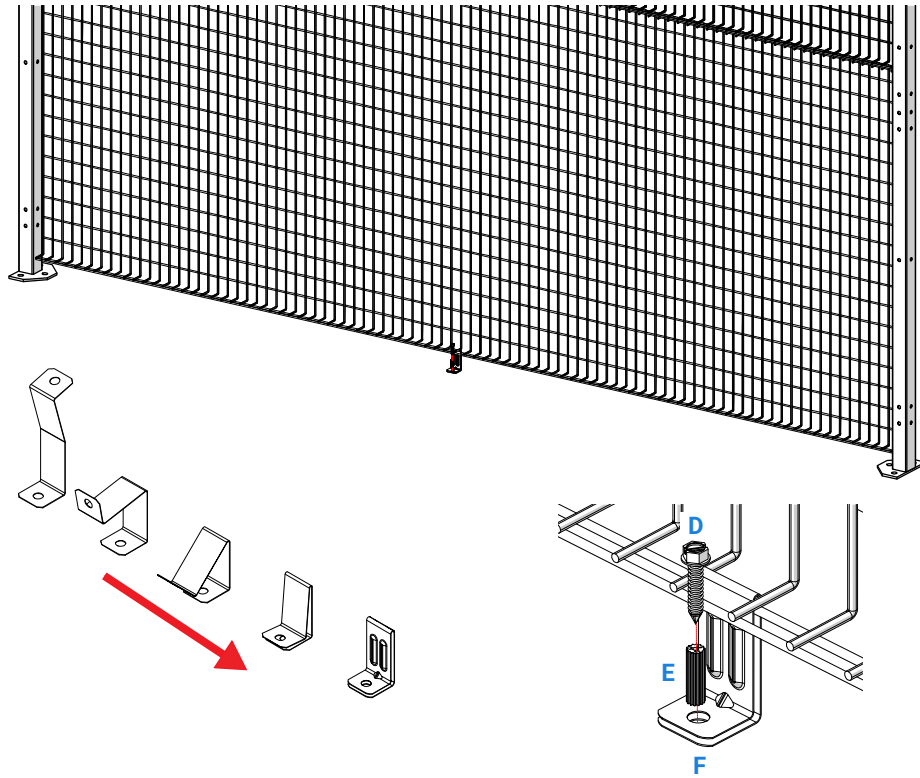

8

OPTIONAL CAPPING CHANNEL

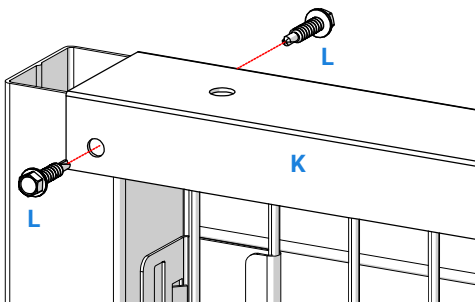
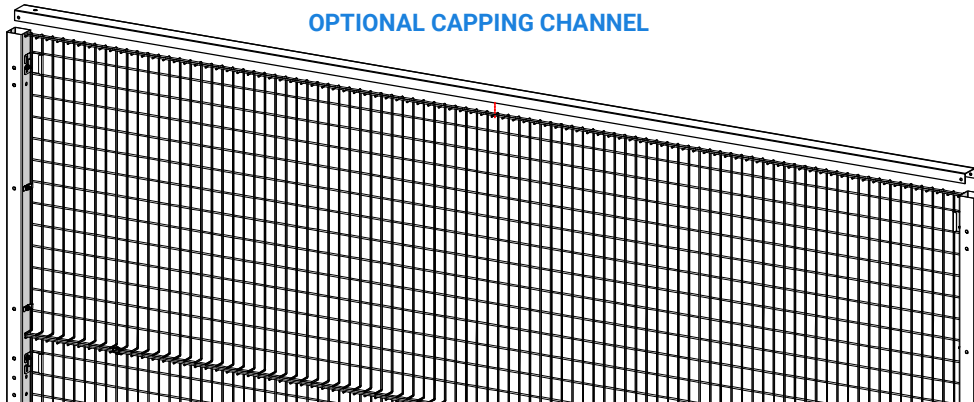

**KT6075**

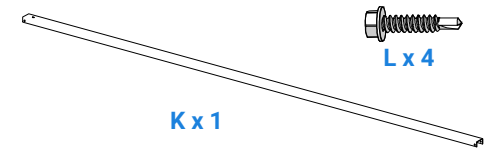

**K x 1**

**L x 4**

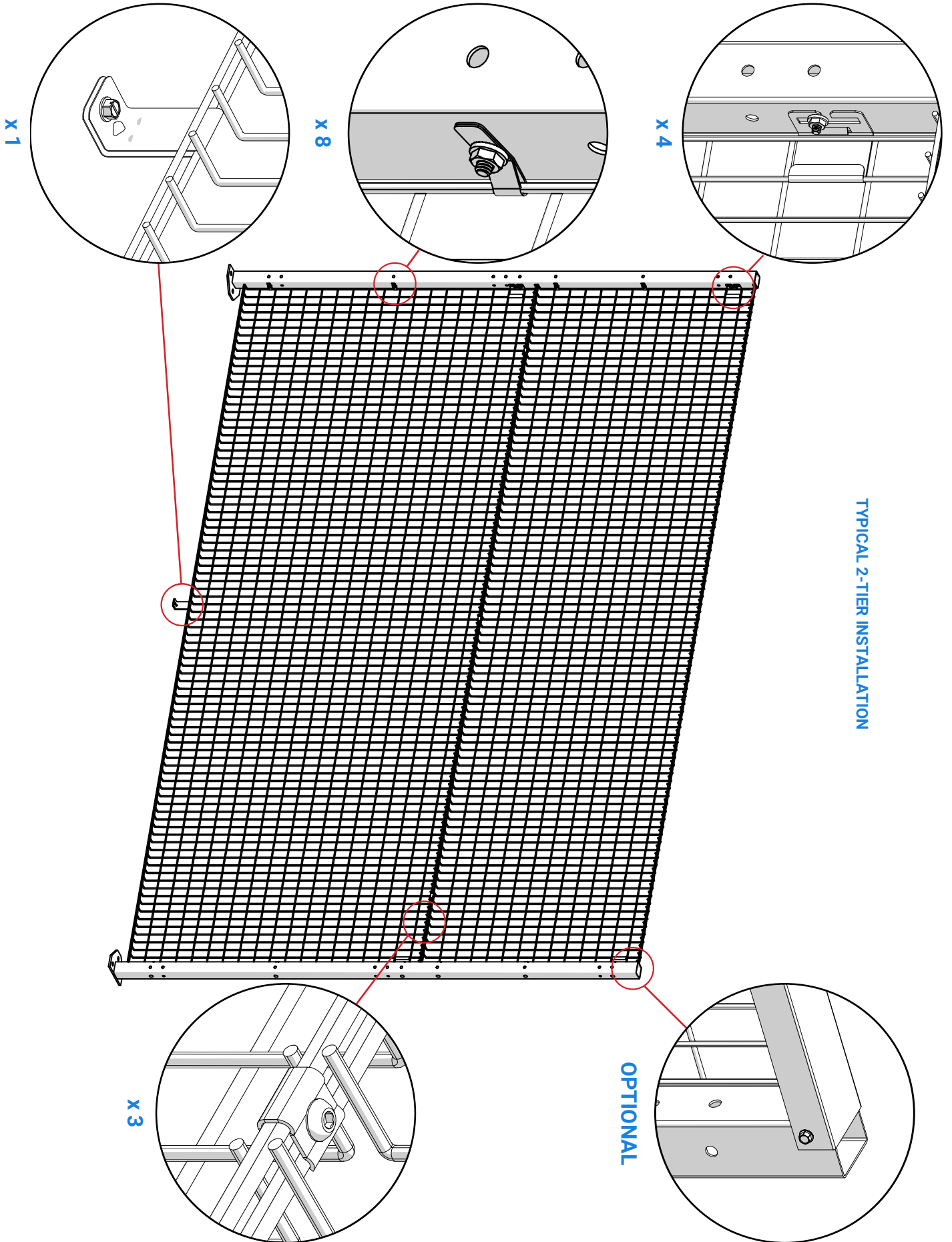

HARDWARE KIT USE TO INSTALL CAPPING CHANNEL

HARDWARE LIST	
L	12-14 x 1" Hex Washer Head Zinc Plated Drill and Tap Screw

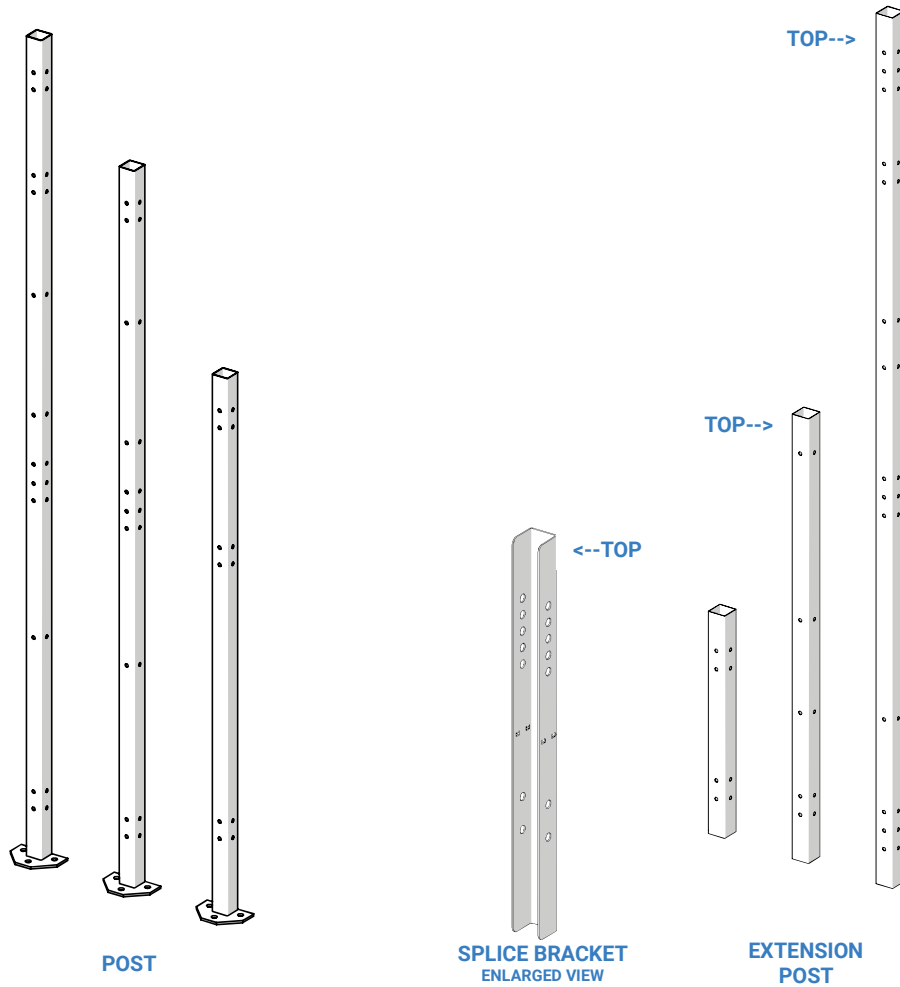

TYPICAL 2-TIER INSTALLATION

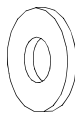
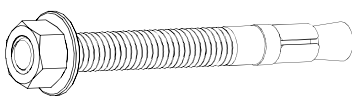
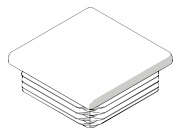

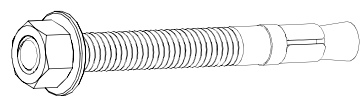
KT312 x1			KT52205	
				
<b>B x 2</b>	<b>A x 2</b>	<b>C x 1</b>	<b>B x 10</b>	<b>A x 10</b>
HARDWARE KIT FOR ANCHORING POST INTO CONCRETE			OPTIONAL ANCHOR KIT (ADDITIONAL ANCHORS)	

HARDWARE LIST	
A	3/8" x 3-3/4" WEDGE ANCHOR (FOR CONCRETE FLOOR)
B	3/8" USS FLAT WASHER
C	TUBE PLUG

**POST ARE FURNISHED STANDARD WITH 2 ANCHORS EACH.  
FOR ADDITIONAL ANCHORS, ORDER **KT52205** (10 ANCHORS)**



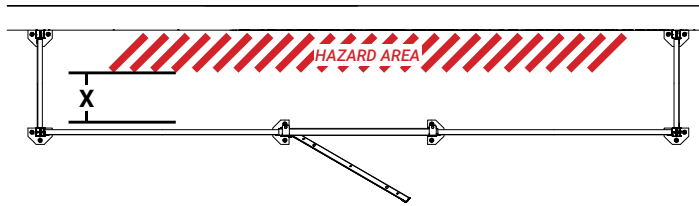

**SAFETY DISTANCE 'X' FROM THE HAZARD AREA IN ACCORDANCE WITH ISO 13857 STANDARDS**

**BASE PLATES POSITIONED TO ALLOW FOR CLEAR DOORWAY EGRESS**

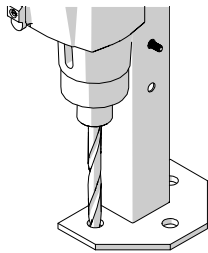

**MARK AND DRILL 3/8" X 2-1/2" DEEP HOLES**

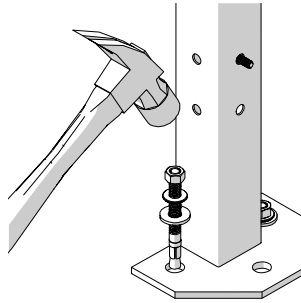

**HAMMER IN WEDGE ANCHOR**

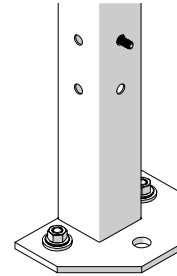

**SECURE POST BY TIGHTENING NUTS**

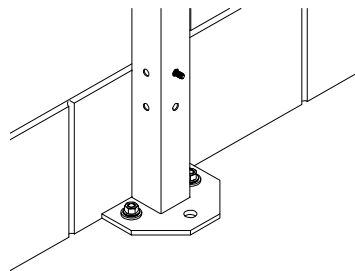

**STANDARD INSTALLATION - 2 ANCHORS PER BASEPLATE REQUIRED**

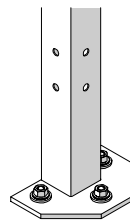

**HEAVY DUTY/CORNER INSTALLATION - 3 ANCHORS PER BASEPLATE IF REQUIRED FOR ADDITIONAL ANCHORS ORDER KT52205**

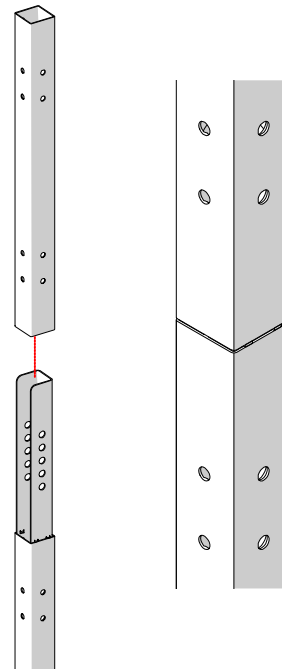

**POST, EXTENSION POST, AND SPLICE BRACKET ARE SECURED WITH HARDWARE THAT IS INCLUDED WITH PANELS**

**NOTE:**

- **UNIQUE BASE PLATE ALLOWS FOR MOUNTING FLUSH TO A WALL / OBSTACLE, OR UTILIZED FOR STANDARD GUARDING**
- **WHEN A POST IS INSTALLED AGAINST A WALL OR OBSTACLE PRE-INSTALL CARRIAGE BOLTS THROUGH POST HOLES BEFORE ANCHORING**
- **FOR SEVERELY UNEVEN FLOORS USE SHIM WASHERS UNDER THE BASE PLATE TO LEVEL POST**